

メス機構 2  
TRIMMING DEVICE 2

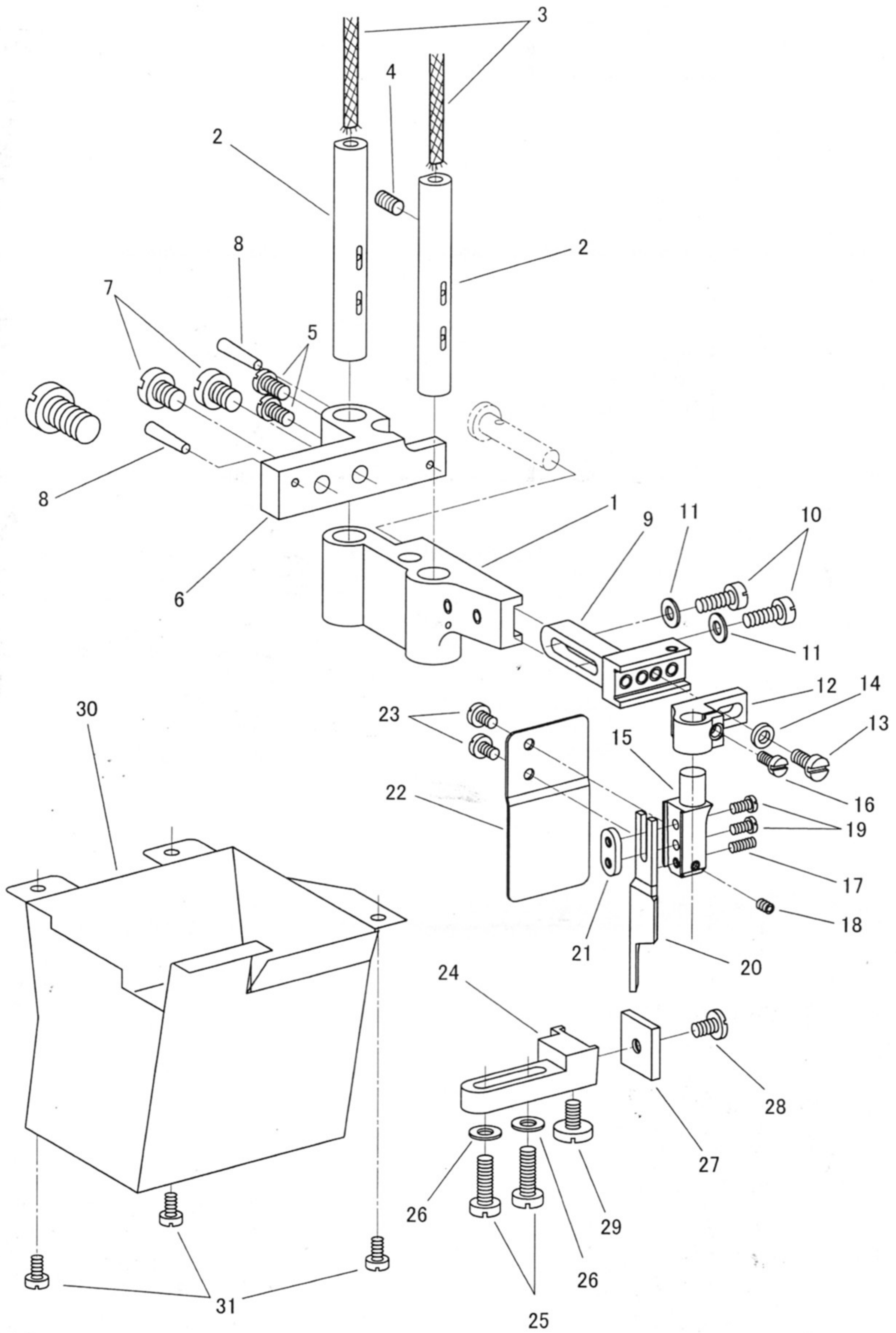



メス機構 2

TRIMMING MECHANISM 2

NO.	部品番号 PARTS NO.	8LVMF	8BLVMF	数量 QTY	品名	DESCRIPTION
1	90507	*	*	1	メス土台	KNIFE SET BASE
2	11432	*	*	2	メス土台ピン	KNIFE SET BASE PIN
3	15570	*	*	2	メス土台ピン油芯	OIL WICK
4	10524-G	*	*	1	メス土台ピン止めねじ(A)	SCREW 6.75X24 L=6.5
5	15055	*	*	2	メス土台ピン止めねじ(B)	SCREW 11/64X32 L=9.0
6	90508	*	*	1	メス土台ピン受台	KNIFE SET BASE GUIDE
7	12361	*	*	2	メス土台ピン受台止めねじ	SCREW 13/64X32 L=14
8	8020-01	*	*	2	メス土台ピン受台ノックピン	TAPER PIN
9	90510	*	*	1	メス補助土台	KNIFE SUPPORTING BASE
10	6025	*	*	2	メス補助土台止めねじ	SCREW 11/64X40 L=12
11	11142	*	*	2	ワッシャー	WASHER
12	11469	*	*	1	メス調節金	KNIFE ADJUSTING PLATE
13	6025	*	*	1	メス調節金止めねじ	SCREW 11/64X40 L=12
14	11142	*	*	1	ワッシャー	WASHER
15	90511	*	*	1	メスホルダー	KNIFE HOLDER
16	8060	*	*	1	メス調節金締めねじ	SCREW 9/64X40 L=8
17	10629	*	*	1	カミソリ止めねじ	SCREW 1/8X40 L=8
18	10630	*	*	1	カミソリ決めねじ	SCREW 1/8X40 L=5
19	8044	*	*	2	メス止め板締めねじ	SCREW 1/8X44 L=6
20	90512	*	*	1	上メス	UPPER KNIFE
21	11437	*	*	1	メス止め板	KNIFE SET WASHER
22	90514	*	*	1	切り屑落としカバー	DUST COVER (UPPER)
23	15039	*	*	2	切り屑落としカバー止めねじ	SCREW 1/8X44 L=3.5
24	90525	*	*	1	下メス受台(標準)	LOWER KNIFE BASE (STANDARD)
25	6323	*	*	2	下メス受台止めねじ	SCREW 3/16X32 L=14.5
26	16287	*	*	2	下メス受台止めねじワッシャー	WASHER
27	90523	*	*	1	下メス	LOWER KNIFE
28	90524	*	*	1	下メス止めねじ	SCREW 11/64X40 L=7.2
29	10559	*	*	1	下メス受ねじ(標準)	SUPPORT SCREW 4.5X32 L=8 (STANDARD)
30	90530	*	*	1	切り屑排出カバー	DUST COVER (LOWER)
31	6333	*	*	3	切り屑排出カバー止めねじ	SCREW 9/64X40 L=6.5