

# *Puller Collection* 拖輪系列

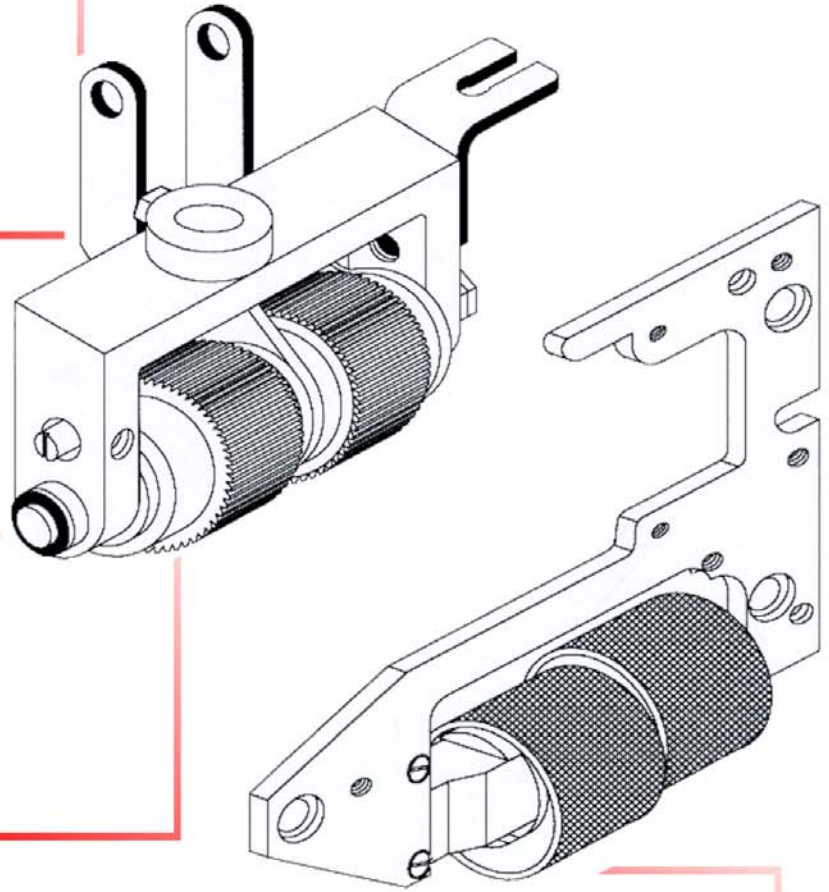

**K**®

拖輪系列 **K**<sup>®</sup> Collection of Puller

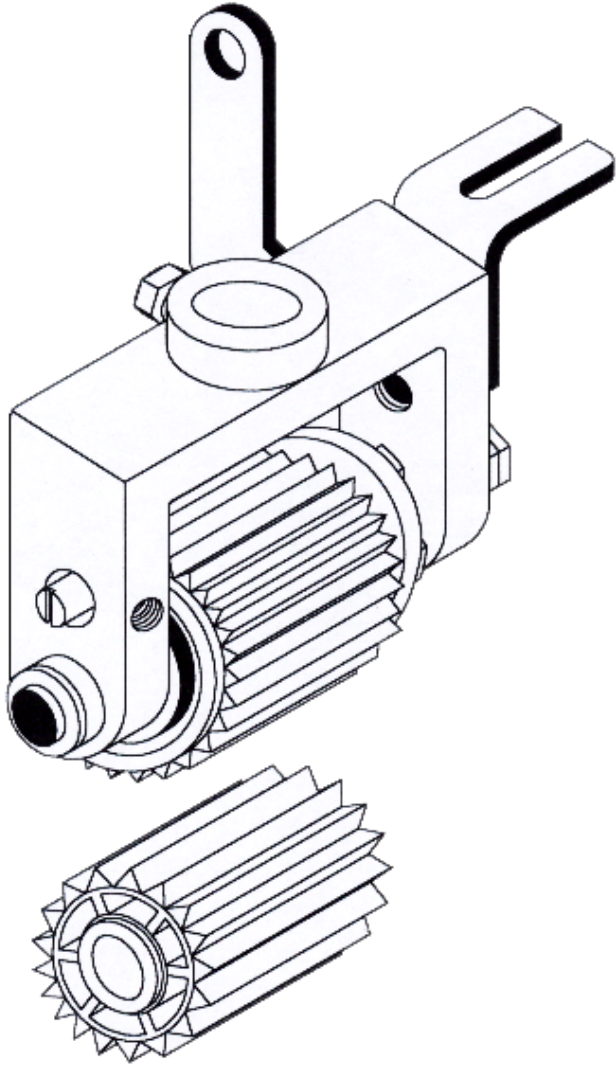

1404P 22T+18T

**00-222**

Rear Puller Gear 22 Teeth (Nylon) Assembly  
22 齒尼龍後拖輪組件

**02-207**

Rear Puller Gear 18 Teeth (Nylon)  
18 齒尼龍後拖輪

1404P 28T+23T  
(1508P 28T+23T)

**00-228**

Rear Puller Gear 28 Teeth (Nylon) Assembly  
28 齒尼龍後拖輪組件

**02-208**

Rear Puller Gear 23 Teeth (Nylon)  
23 齒尼龍後拖輪

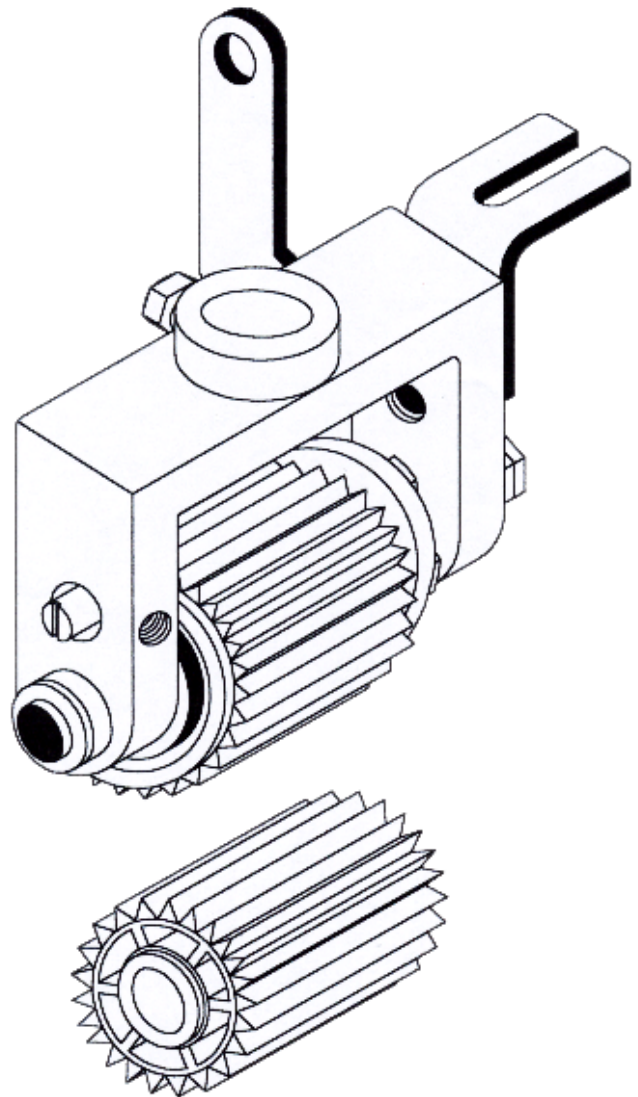

拖輪系列 **KI**<sup>®</sup> Collection of Puller

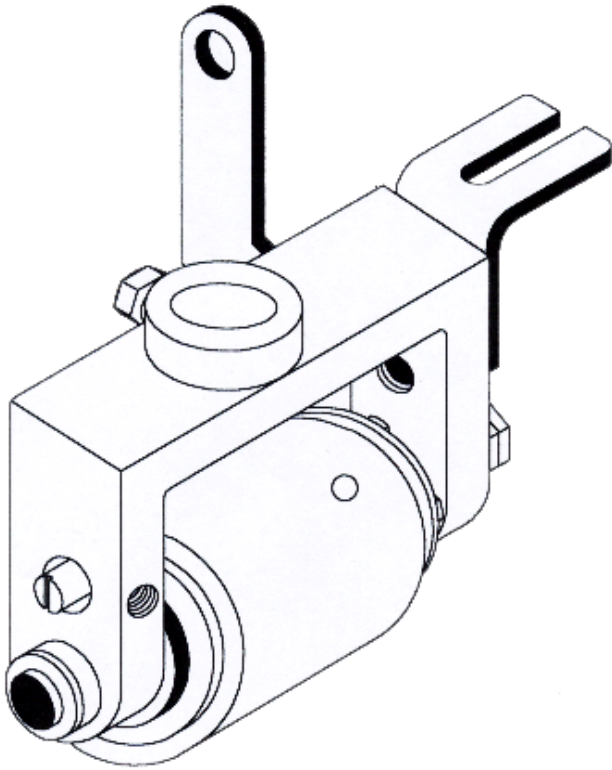

1404PSF (1508PSF)

**00-200** Rear Puller (Smooth) Assembly  
光面膠後拖輪組件

**02-197** Rear Puller (Smooth)  
光面膠後拖輪

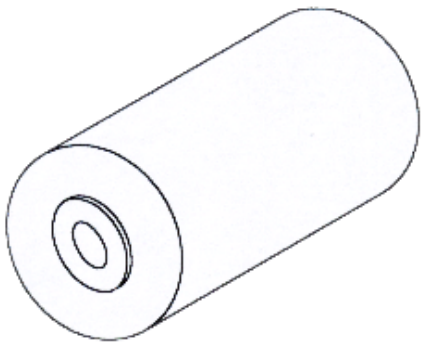

1404P (1508P)

**00-201** Rear Puller, Rouletted Roller Assembly  
滾花鋼後拖輪組件

**02-197** Rear Puller (Smooth)  
光面膠後拖輪

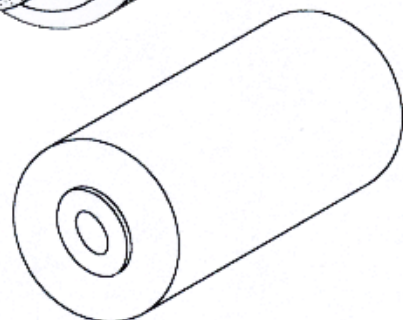
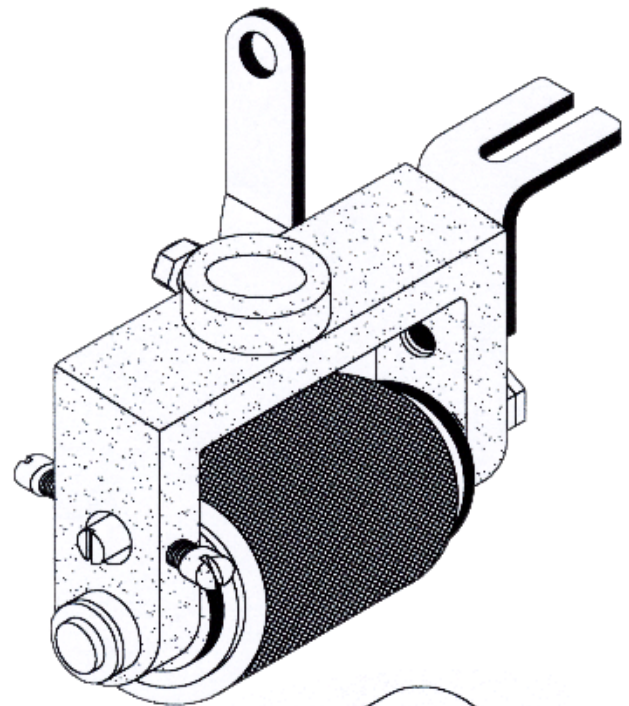

拖輪系列 **KI**<sup>®</sup> Collection of Puller

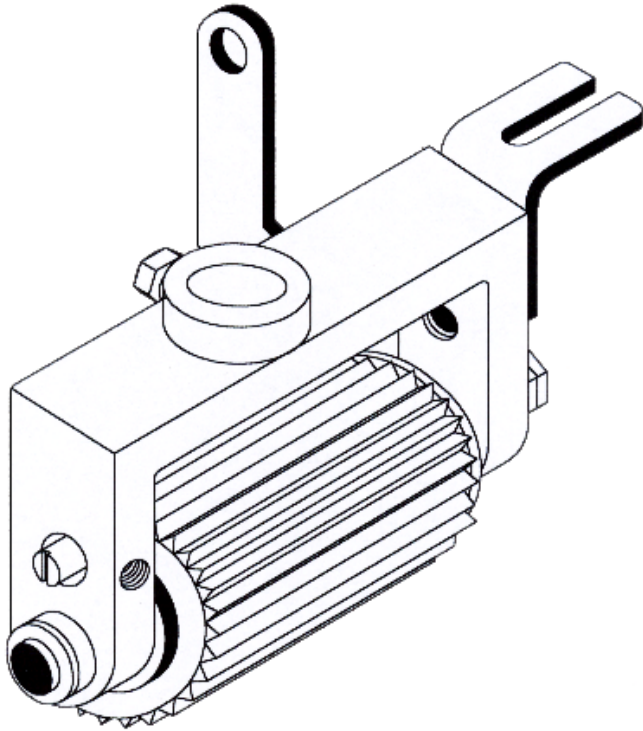

1412P 22T+18T

**00-242**

Rear Puller Gear 22 Teeth (Nylon) Assembly  
22 齒尼龍後拖輪組件

**02-478**

Rear Puller Gear 18 Teeth (Nylon)  
18 齒尼龍後拖輪

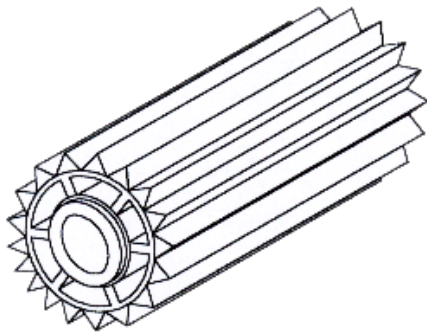

1412P 28T+23T

**00-248**

Rear Puller Gear 28 Teeth (Nylon) Assembly  
28 齒尼龍後拖輪組件

**02-479**

Rear Puller Gear 23 Teeth (Nylon)  
23 齒尼龍後拖輪

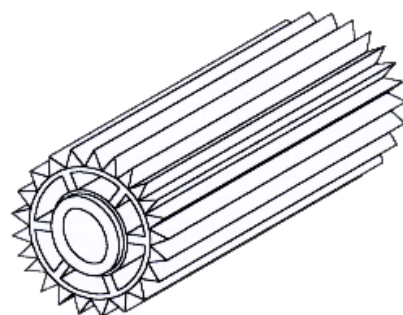
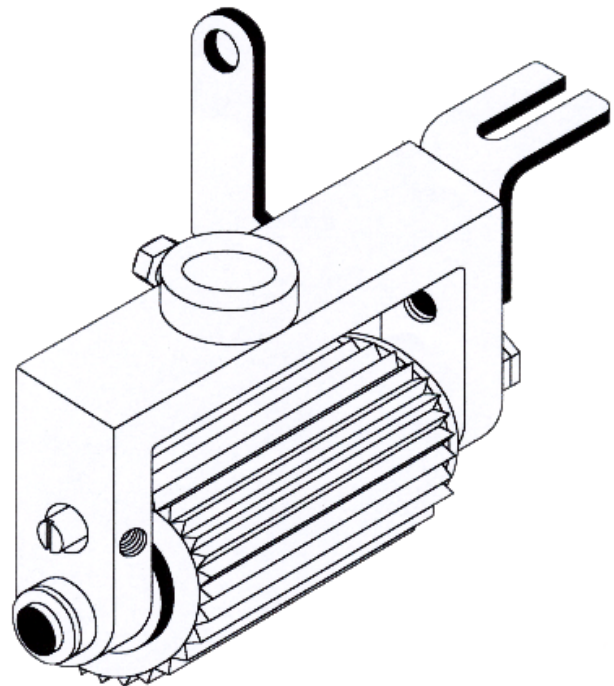

拖輪系列 **KI**<sup>®</sup> Collection of Puller

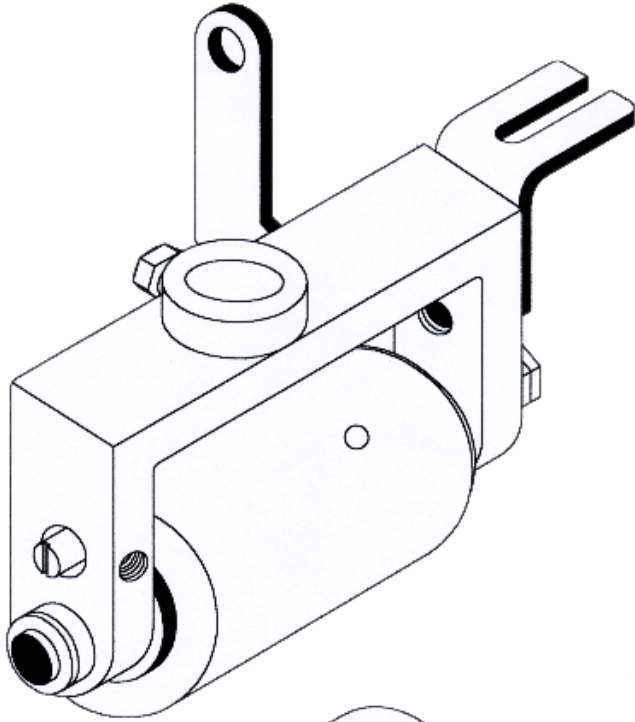

1412PSF

**00-240** Rear Puller (Smooth) Assembly  
光面膠後拖輪組件

**02-476** Rear Puller (Smooth)  
光面膠後拖輪

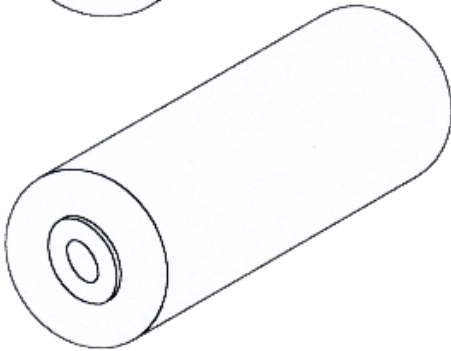

1508P

**00-260**  
Rear Puller Gear 60 Teeth (Steel) Assembly  
60 齒鋼後拖輪組件

**02-197**  
Rear Puller (Smooth)  
光面膠後拖輪

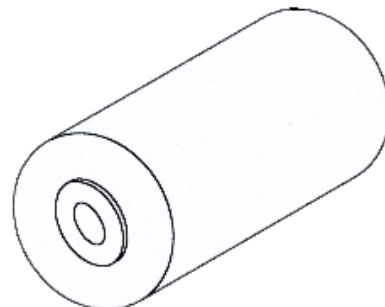
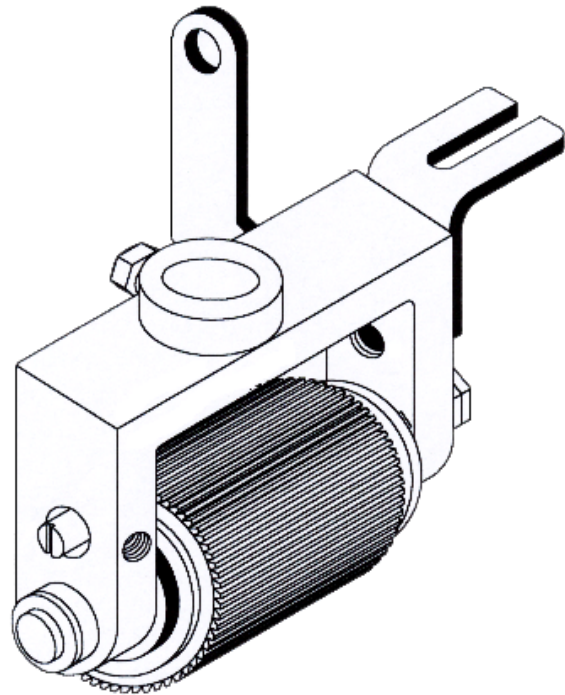

拖輪系列 **KI**<sup>®</sup> Collection of Puller

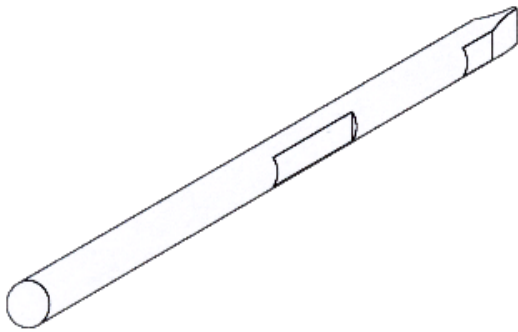
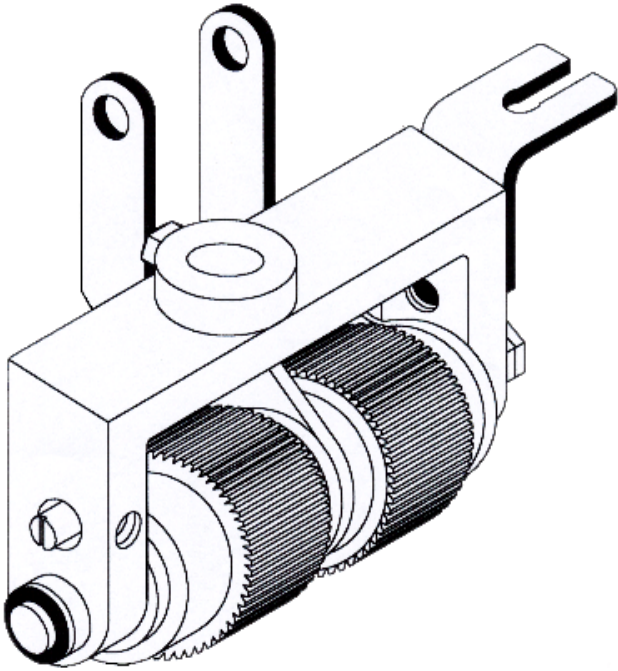

1508PD

**00-0610-0**

Upper Double Puller Assembly  
上層拖輪組件

**00-2050-0**

Lower Double Puller Assembly  
下層拖輪組件

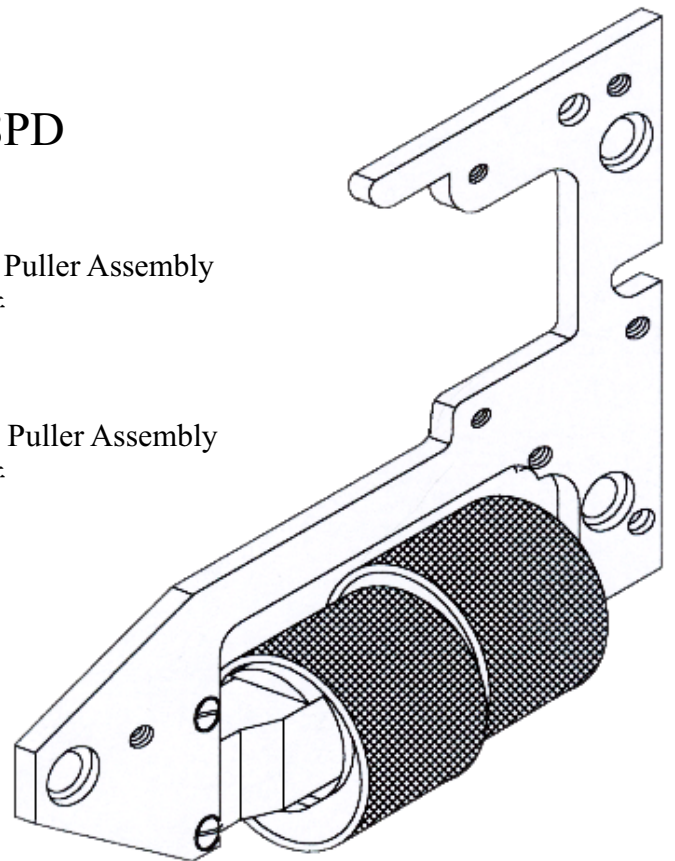

# 拖輪系列 **KI**<sup>®</sup> Collection of Puller

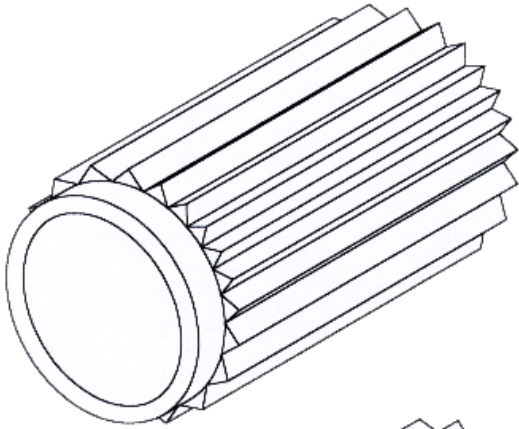

**02-177** Upper Gear 上齒輪

**02-207** Lower Gear 下齒輪

22T+18T Nylon Gear for 1404P  
22 齒及 18 齒尼龍齒輪, 1404P 用

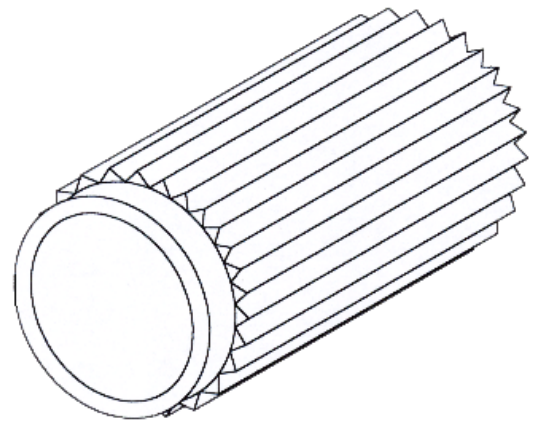
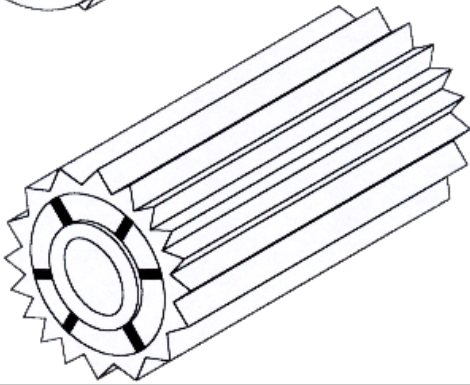

**02-178** Upper Gear 上齒輪

**02-208** Lower Gear 下齒輪

28T+23T Nylon Gear for 1404P & 1508P  
28 齒及 23 齒尼龍齒輪, 1404P 及 1508P 用

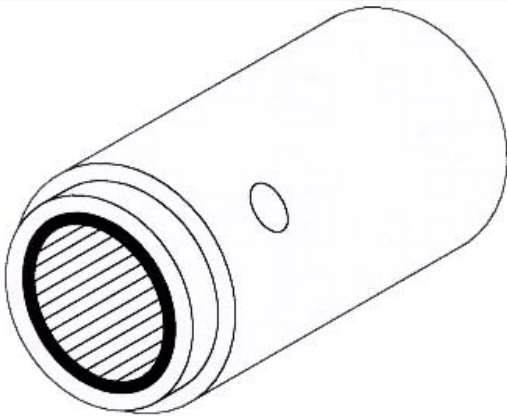
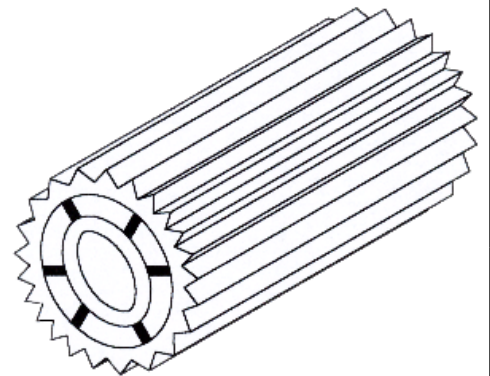

**02-181** Upper Gear 上光面膠輪

**02-197** Lower Gear 下光面膠輪

Smooth Puller for 1404PSF, 1508PSF  
光面膠輪, 1404PSF, 1508PSF 用

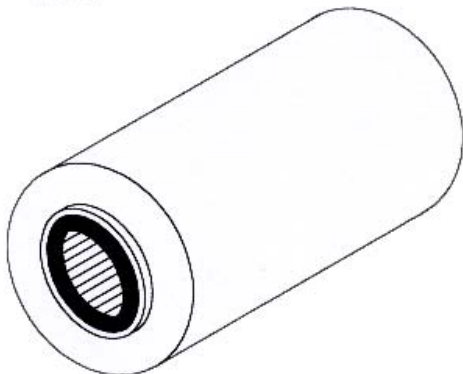

# 拖輪系列 **KI**<sup>®</sup> Collection of Puller

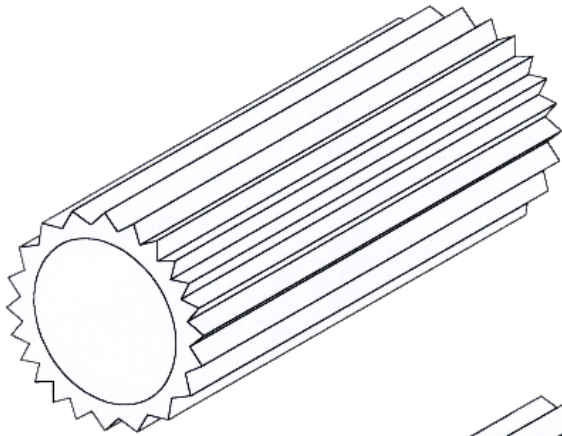

**02-473** Upper Gear 上齒輪

**02-478** Lower Gear 下齒輪

22T+18T Nylon Gear for 1412P

22 齒及 18 齒尼龍齒輪, 1412P 用

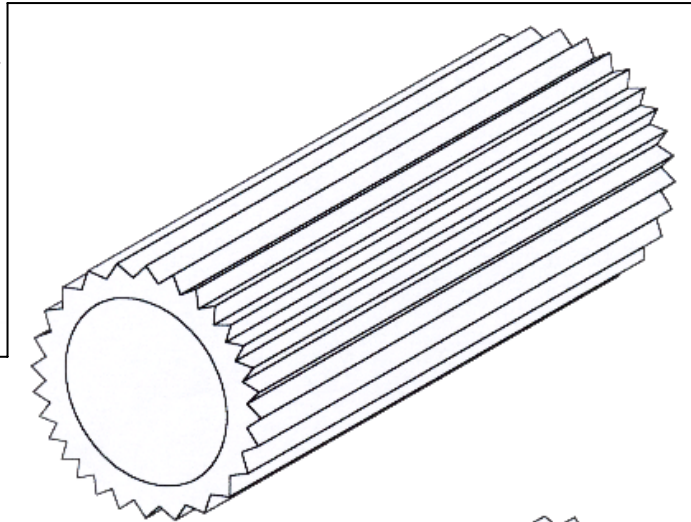
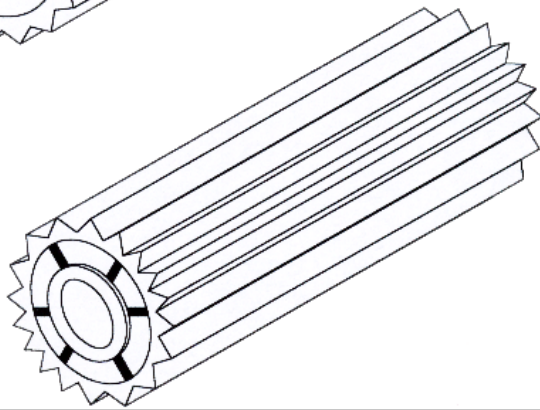

**02-474** Upper Gear 上齒輪

**02-479** Lower Gear 下齒輪

28T+23T Nylon Gear for 1412P

28 齒及 23 齒尼龍齒輪, 1412P 用

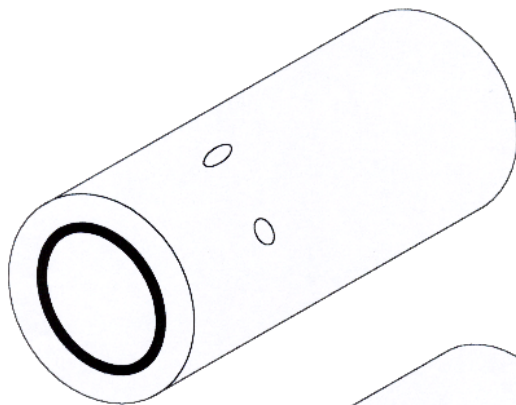
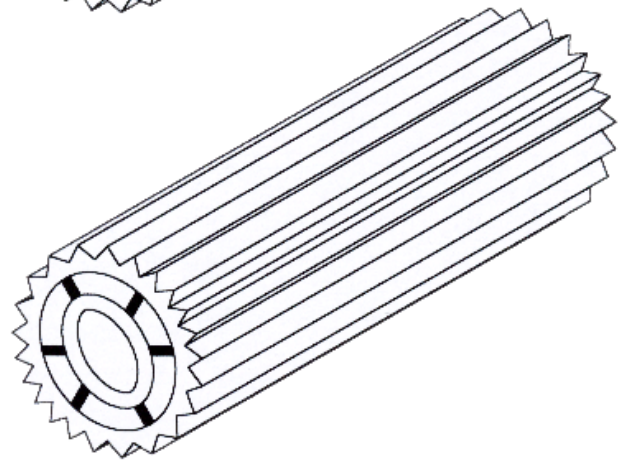

**02-471** Upper Gear 上光面膠輪

**02-476** Lower Gear 下光面膠輪

Smooth Puller for 1412PSF

光面膠輪, 1412PSF 用

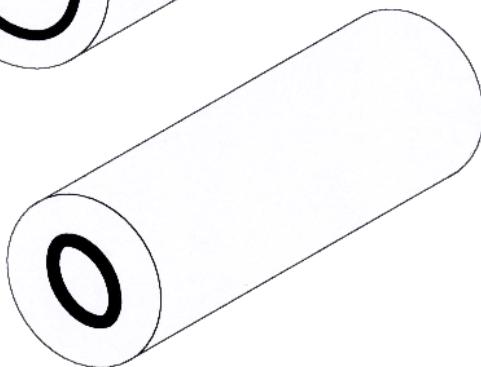



# 拖輪系列 Collection of Puller

Upper 上	Lower 下	
02-175	02-197	60T Steel Gear with Smooth Roller for 1508P 60 齒鋼齒輪及光面膠輪, 1508P 用
02-448	02-197	Smooth Puller for 1508PSF 光面膠拖輪, 1508PSF 用
02-184	02-197	Rouletted Steel Roller with Smooth Roller for 1508P 滾花鋼輪及光面膠輪, 1508P 用

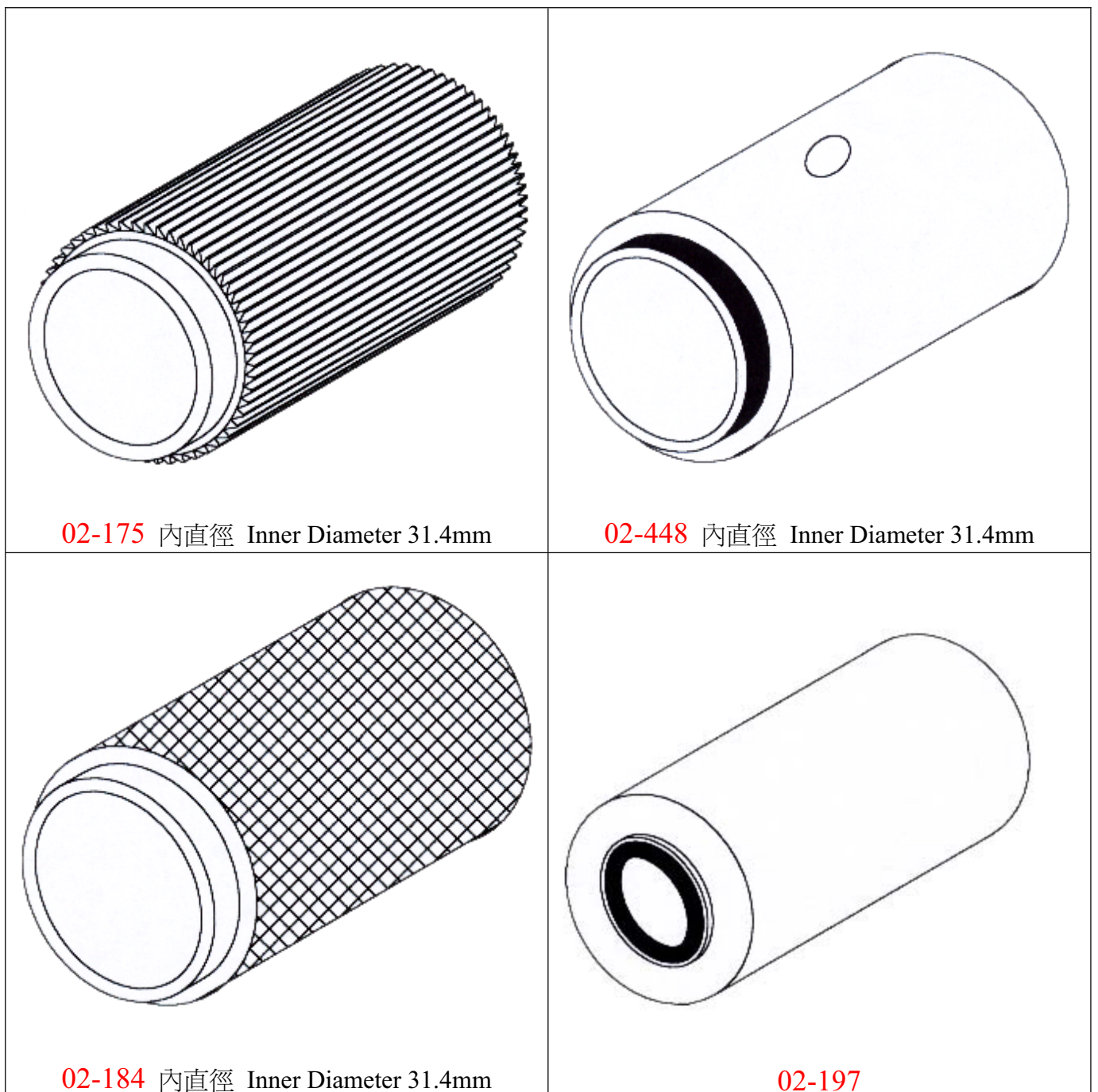

拖輪系列 **K**<sup>®</sup> Collection of Puller

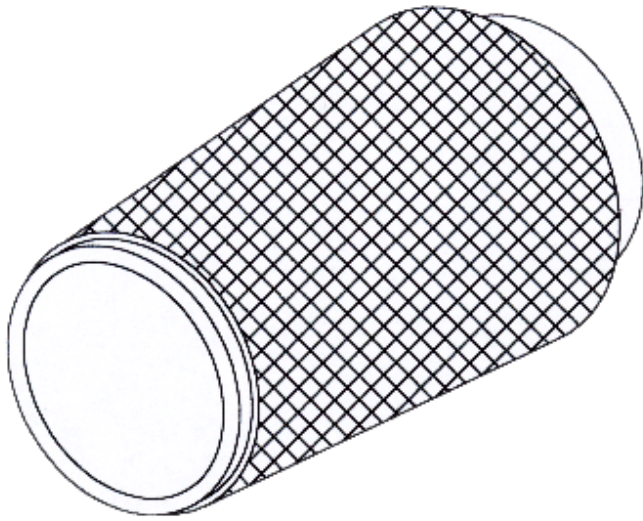

**02-184cu** Upper roller 上滾花鋼輪  
外圓直徑 Inner Diameter 42mm & 47mm

**02-197cu** Lower roller 下滾花鋼輪  
外圓直徑 Inner Diameter 35mm & 41mm

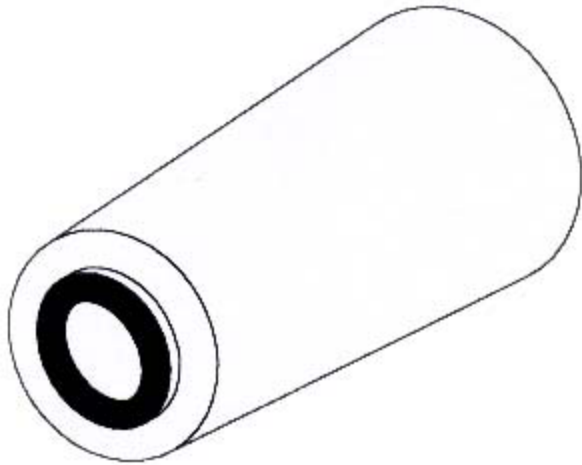

Rouletted Steel Roller with Smooth Roller  
for 1508P Curve Waist Band  
滾花鋼輪及光面膠輪, 1508P 彎褲頭用

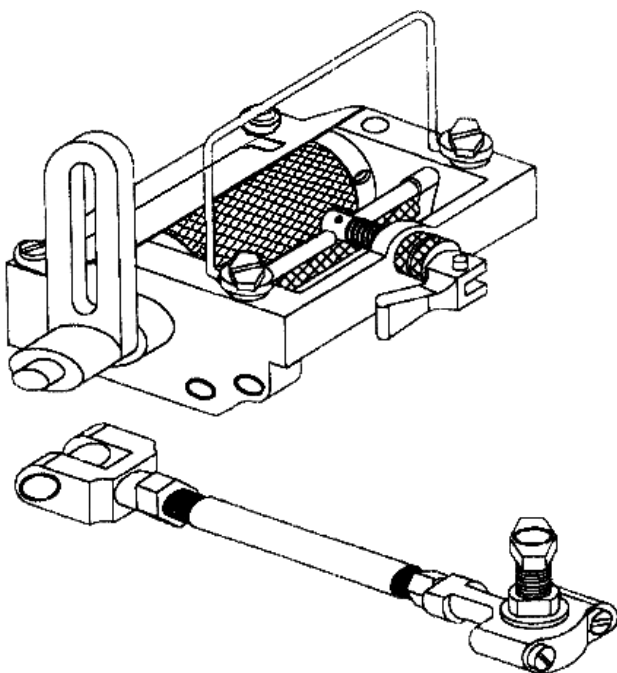

**1404PMD 00-140-04**

Front Elastic Feeder with Connecting Assembly  
前送料器及連結組件

拖輪系列 **KI**<sup>®</sup> Collection of Puller

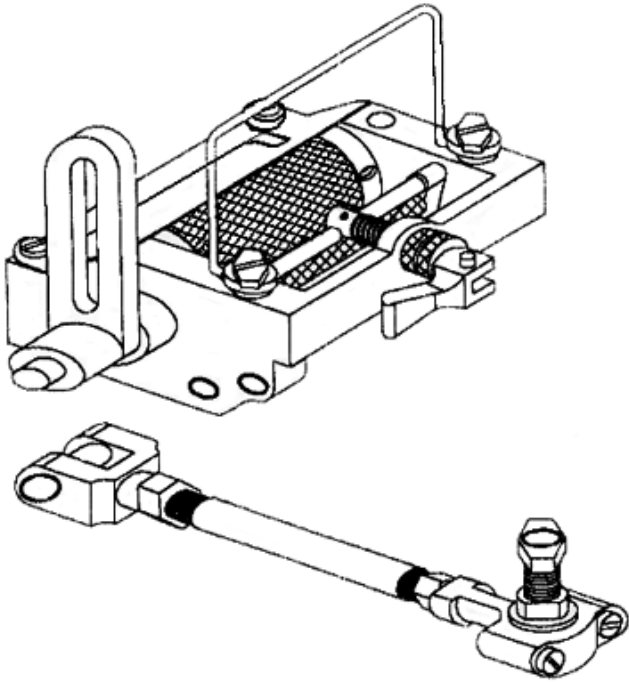

1412PMD 00-140-12

Front Elastic Feeder with Connecting Assembly  
前送料器及連結組件

US 51800

29476GG (54278S)

Feed Roller for Union Special 51800  
於仁 51800 送料滾輪

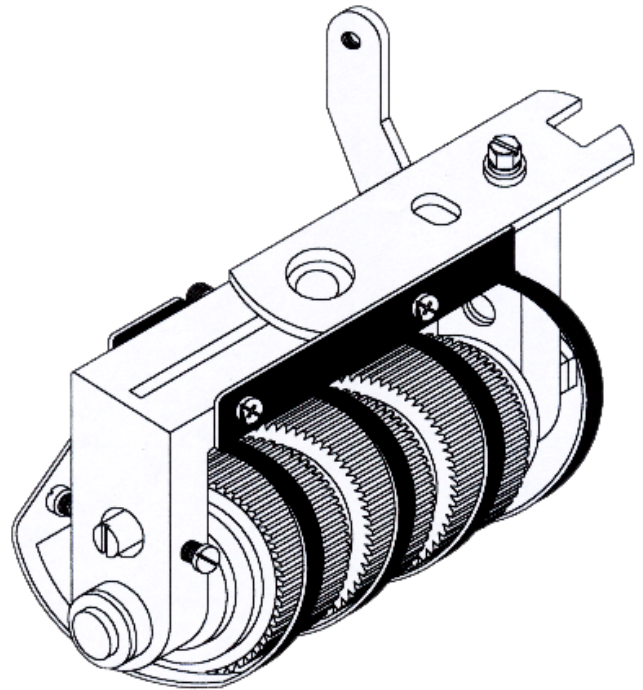

 *Puller Collection*  
拖輪系列 



國興針車公司

Kwok Hing Sewing Machine Co.

九龍荔枝角道 107 號地下

G/F., 107 Lai Chi Kok Road, Kowloon, Hong Kong

Tel : (852) 2394 8163 Fax : (852) 2789 2681

Website : <http://www.kwokhing.com>

E-mail : [spareparts@kwokhing.com](mailto:spareparts@kwokhing.com)